

ITEM NO.	PART NO.	DESCRIPTION	QTY.
1	H273	nut, kep, #10-32 zinc	8
2	H230	screw, 10-32 x 1/2" phil pan head, s/s	2
3	H528	bracket, heater mounting, dual	1
4	E571	heating rod, 600W, 115V	2
5	H274	screw, 6 x 3/16, phil pan head, self-tapping	10
6	E574	Thermostat, 310°F ± 10°F, Manual, 1/4"	2
7	E573	Thermostat, 200°, Auto, 1/4"	2
8	H903A	heater, aluminum cast, single	2
9	B103	elbow, 90 deg street, 1/4"mpt x 1/4" fpt	5
10	B207	elbow, brass, 90 deg, 1/4" fpt x 1/4" fpt	2
11	AH156	hose, 3/8" x 6.5", (OAL), f x fsw, 5400 Gray	1
12	B113	tee, 1/4" fpt x 1/4" fpt x 1/4" fpt	1
13	AH120	sol hose, 1/4" X 24.5", 1/4 MSW X 1/4 FPT	1
14	B541	valve, relief, 250 psi	1
15	B109	barb, 1/4" barb x 1/4" mpt	1
16	B170	ferrule, 1/4" brass	2
17	PH634-26	sol hose, 1/4", silicone braided, clear	1
18	B110	adapter, brass, 1/4" sw barb x 1/4" fpt, w/gasket	1
19	B108	valve, brass, 1/4" check	1
20	AH184	sol hose, 1/4" x 14.5" OAL, 1/4" msw x 1/4" fpt	1
21	B142	coupling, 1/4" fpt x 1/4" fpt	1
22	B652	elbow, 90 deg, 3/8"mpt x 1/4"mpt	1
23	C305	pump, 120 psi, 115V	1
24	H222	screw, 10-32 x 1-1/4" phil pan head, s/s	4
25	H210	washer, 1/4" flat, s/s	27
26	B172	elbow, brass, 90 deg, 1/2" barb x 3/8"mpt	1
27	H347	clamp, hose, 5/16-29/32	2
28	PH615-29	sol hose, 1/2" kuri 100psi	1
29	B160	adapter, brass, 1/2" barb x 3/8" fsw, ball end	1
30	E531	power cord, end, 25', 12/3 black	1
31	H220	fitting, strain relief, cord	1
32	H221	nut, lock, 1/2" steel, electrical	1
33	P791	base, spyder	1
34	H296	guard, cooling fan, wire	2
35	H304	screw, 8 x 5/8", phil oval, s/s	14
36	H194	coupler, 2" dia x 3" length, s/s	1
37	H124V	CUFF-LYNX, 2" female cuff X 2" male thread starter cuff	1
38	H020	nut, lock, 2", steel	1
39	H216	nut, lock, 1/4-20, nylon insert, s/s	18
40	H342	bolt, 1/4-20 x 1" hex head, s/s	16
41	H667	caster, 3", Black Hub, Gray Tread	4
42	P792	sol tank, spyder	1
43	H215	nut, hex, 1/4-20 s/s	1
44	H213	washer, 1/4" lock, s/s	5
45	H211	washer, 1/4" id x 1" od, flat, s/s	2
46	G052	washer, buna 1-1/8" od x 3/16" id	2
47	H203	bolt, 1/4-20 x 1-1/4" hex head, s/s	1
48	P965	cover, sol tank, spyder	1
49	H316	bolt, 1/4-20 x 1-1/2" hex head, s/s	2
50	H379	bracket, front, small	1
51	H201	bolt, 1/4-20 x 1/2" hex head, s/s	2
52	B119	filter, strainer, 1/4"	1
53	B107	nipple, hex, 1/4"mpt x 1/4"mpt	3
54	H212	flat washer, 9/16"ID x 1 1/16"OD, AN960-C916	7
55	B105	bushing, brass, 3/8"mpt x 1/4"	1
56	B102	quick disconnect, 1/4" fqd x 1/4" fpt	1
57	AH106	sol hose, 1/4" x 10", 1/4" msw x 1/4" fpt	1
58	H770	bolt, 1/4-20 x 1/2" serrated hex flange, zinc	8
59	H912	bracket, rear, fb/spy	1
60	P793	vac tank, spyder	1
61	H135V	Cuff-Lynx, 2" male cuff x 2" mpt, vinyl	1
62	H314	nut, lock, 1-1/2", steel	1

ITEM NO.	PART NO.	DESCRIPTION	QTY.
63	P520	adapter, 1.5" mpt pvc	1
64	PH633-4	pipe, pvc, 1-1/2"	1
65	P503	adapter, 1.5" pvc, 45 deg, fslip	2
66	PH633-2.5	pipe, pvc, 1-1/2"	1
67	PH633-.25	pipe, pvc, 1-1/2"	1
68	G097	filter, screen mesh, 1.90" dia	1
69	G003	filter, foam, 2", vac stack, 1/2"	1
70	G090	lid, vac tank, clear, 7"	1
71	G091	gasket, 7", vac lid	1
72	A926	elbow, inlet assembly 2"	1
73	H225	valve, drain, 1-1/2"	1
74	H390A	bracket, "L", 2" x 2"	2
75	PH628	vac hose, 2", black, wire reinforced	1
76	H217	clamp, hose, 2-1/4 dia	2
77	H343	screw, 10 x 5/8" hex head, zinc	1
78	C302LA	vac motor, 3 stage, low amp	1
79	H096	bolt, hex, 1/4-20 x 4", zinc Finish	3
80	H503	vac support, 3 stage, 3.25", no thrds	3
81	G004	gasket, vacuum motor	1
82	H389	screw, 10-32 x 1/2" SHCS, alloy	1
83	H289	washer, 10 flat, s/s	1
84	E515	switch, rocker, 2 position	3
85	H246	screw, 8-32 x 3/8" SHCS, alloy, Black	4
86	H636	plate, switch, ml/trkr, 3 hole	1

**ITEMS NOT SHOWN:**

PART NO.	DESCRIPTION	QTY.
8400P	tool, upholstery, 4", Air Lite	1
8501	hose assem, vac/sol, 15' x 1-1/4", cuff, hose in hose	1
E998	harness, electrical	1
G079	hose wrap, heat guard	1
H226	spout, drain, 45 degree	1
P590	cuties, 1/4" qd, standard pack of 2	1

**COMPONENT ASSEMBLIES**

ITEM NO.	PART NO.	DESCRIPTION	QTY.
	<b>A907</b>	<b>heater assembly, 1200w, 115v</b>	<b>1</b>
4	E571	heating rod, 600W, 115V	2
6	E574	Thermostat, 310°F ± 10°F, Manual, 1/4"	1
7	E573	Thermostat, 200°, Auto, 1/4"	1
8	H903A	heater, aluminum cast, single	2

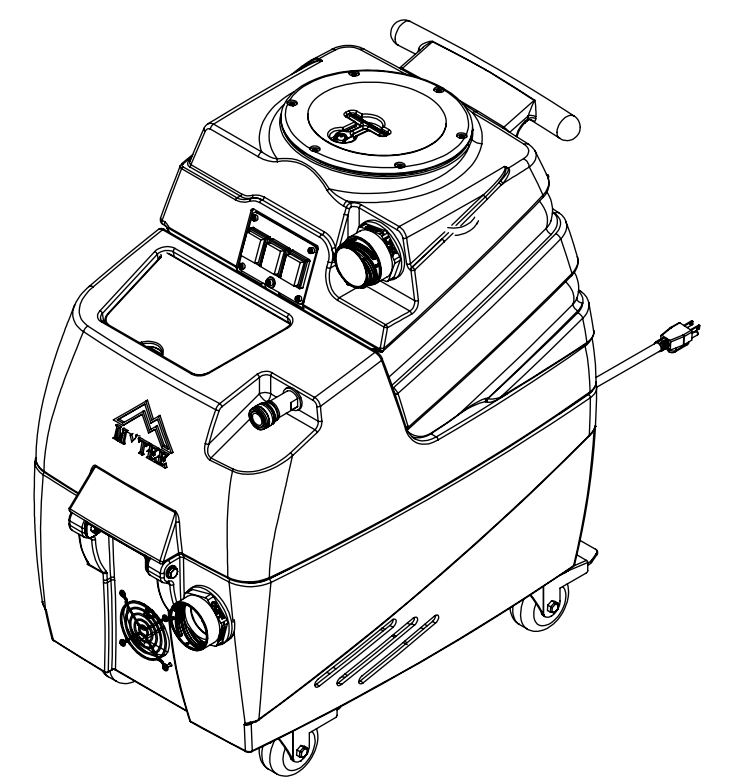

DRAWN	V. LaBarbera	DATE	1/2014	<p><b>MYTEE</b> 858-679-1191</p> <p><b>Spyder</b></p>
CHECKED		TITLE:		
<p><small>PROPRIETARY AND CONFIDENTIAL</small> THE INFORMATION CONTAINED IN THIS DRAWING IS THE SOLE PROPERTY OF MYTEE LLC. ANY REPRODUCTION IN PART OR AS A WHOLE WITHOUT THE WRITTEN PERMISSION OF MYTEE LLC IS PROHIBITED.</p>				<p>SIZE DWG. NO. REV</p> <p><b>C</b> <b>HP60</b> <b>F</b></p>
SCALE: 1:3			DO NOT SCALE DRAWING	SHEET 1 OF 5

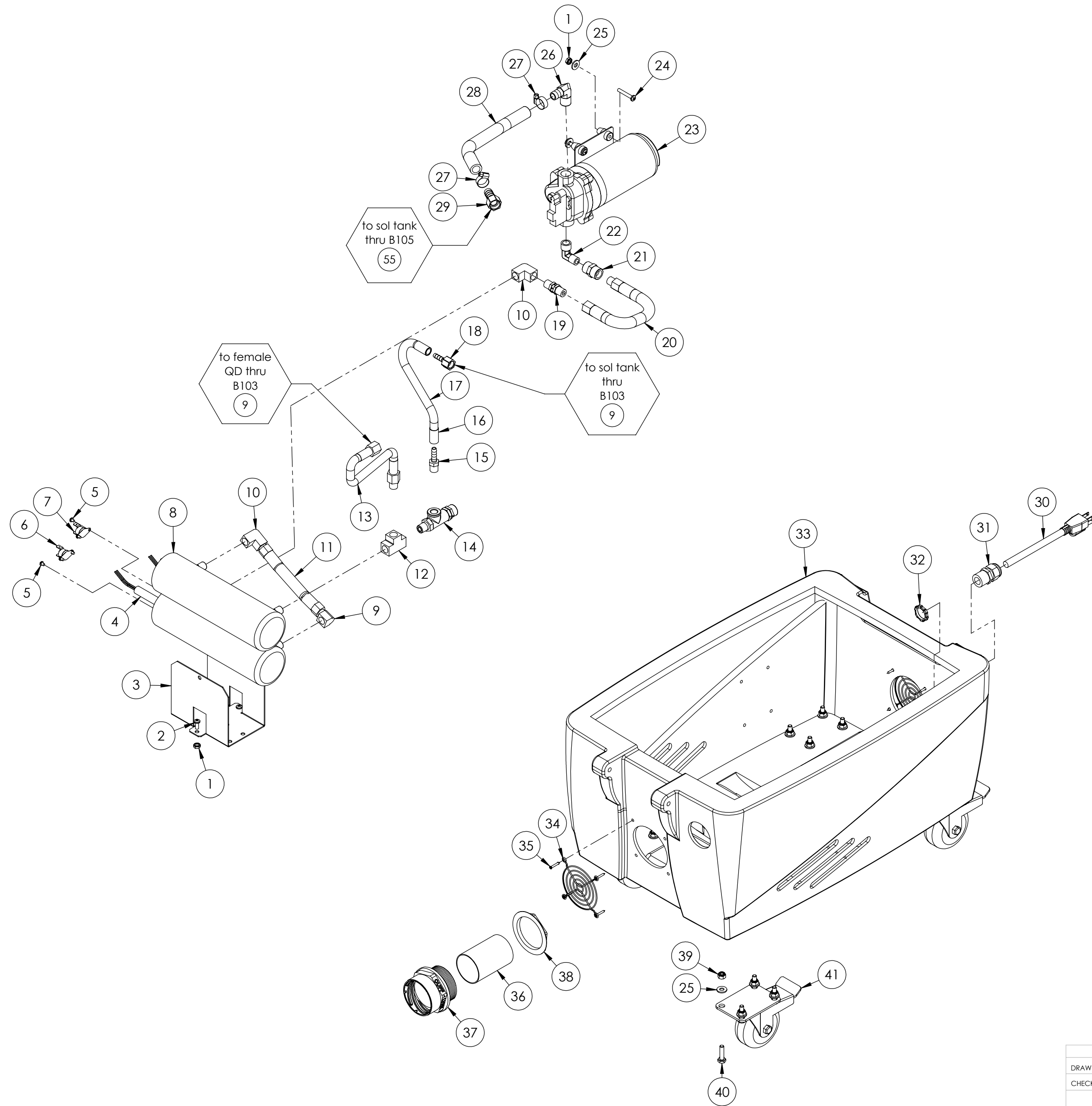

	NAME	DATE	<b>MYTEE</b> 858-679-1191		
DRAWN	V. LaBarberga	1/2014			
CHECKED			TITLE:		
<b>PROPRIETARY AND CONFIDENTIAL</b> THE INFORMATION CONTAINED IN THIS DRAWING IS THE SOLE PROPERTY OF MYTEE LLC. ANY REPRODUCTION IN PART OR AS A WHOLE WITHOUT THE WRITTEN PERMISSION OF MYTEE LLC IS PROHIBITED.			<b>Spyder</b>		
			SIZE	DWG. NO.	REV
			<b>C</b>	<b>HP60</b>	<b>F</b>
			SCALE: 1:5	DO NOT SCALE DRAWING	SHEET 2 OF 5

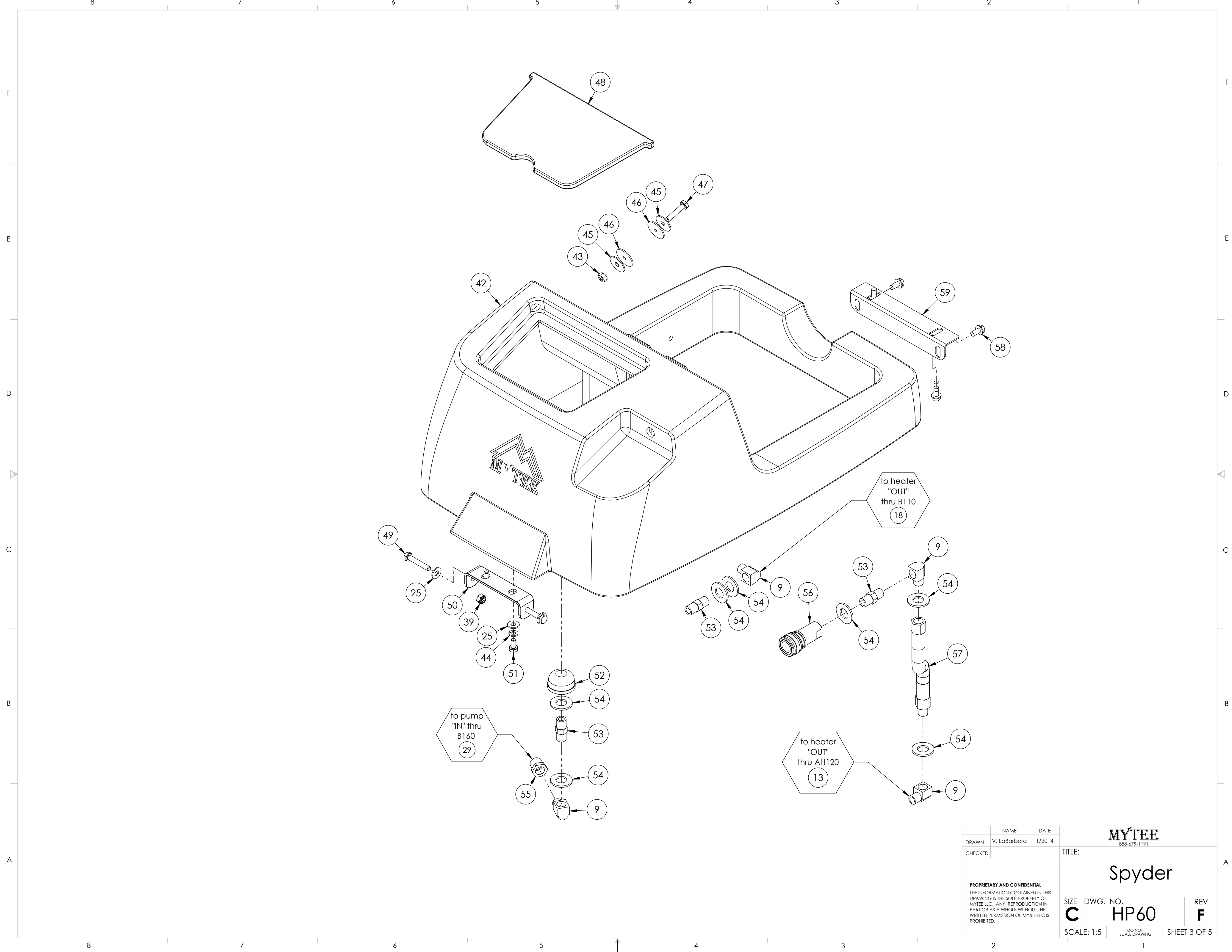

	NAME	DATE	<b>MYTEE</b> 858-679-1191		
DRAWN	V. LaBarberga	1/2014			
CHECKED			TITLE:  <b>Spyder</b>		
<small>PROPRIETARY AND CONFIDENTIAL THE INFORMATION CONTAINED IN THIS DRAWING IS THE SOLE PROPERTY OF MYTEE LLC. ANY REPRODUCTION IN PART OR AS A WHOLE WITHOUT THE WRITTEN PERMISSION OF MYTEE LLC IS PROHIBITED.</small>					SIZE
			<b>C</b>	<b>HP60</b>	<b>F</b>
SCALE: 1:5		DO NOT SCALE DRAWING	SHEET 3 OF 5		

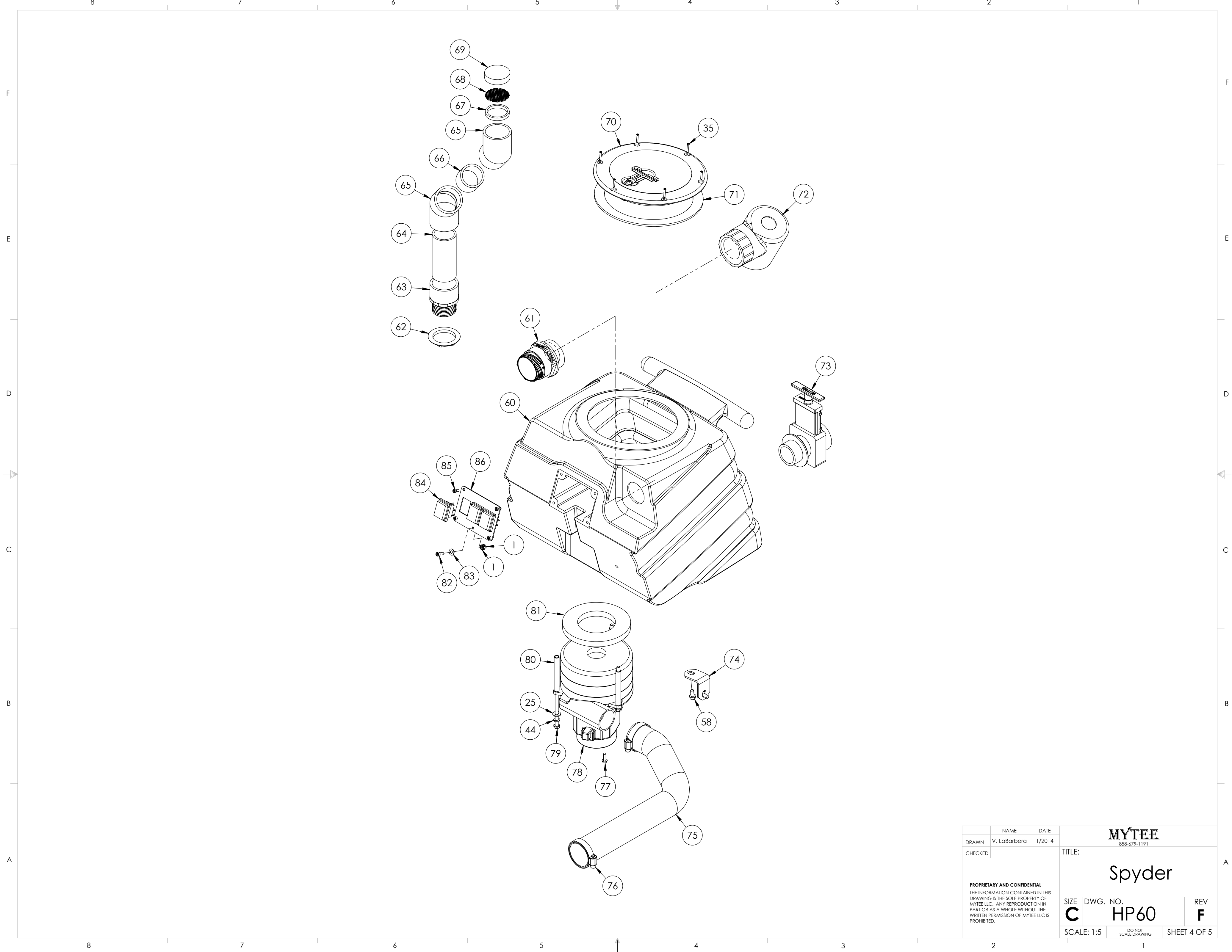

	NAME	DATE	<b>MYTEE</b> 858-679-1191		
DRAWN	V. LaBarberga	1/2014			
CHECKED			TITLE:  <b>Spyder</b>		
<b>PROPRIETARY AND CONFIDENTIAL</b> THE INFORMATION CONTAINED IN THIS DRAWING IS THE SOLE PROPERTY OF MYTEE LLC. ANY REPRODUCTION IN PART OR AS A WHOLE WITHOUT THE WRITTEN PERMISSION OF MYTEE LLC IS PROHIBITED.					SIZE
			<b>C</b>	<b>HP60</b>	<b>F</b>
			SCALE: 1:5	DO NOT SCALE DRAWING	SHEET 4 OF 5

**REVISIONS**

REV.	DESCRIPTION	DATE	APPROVED
OD	ORIGINAL DRAFT	-	JFL

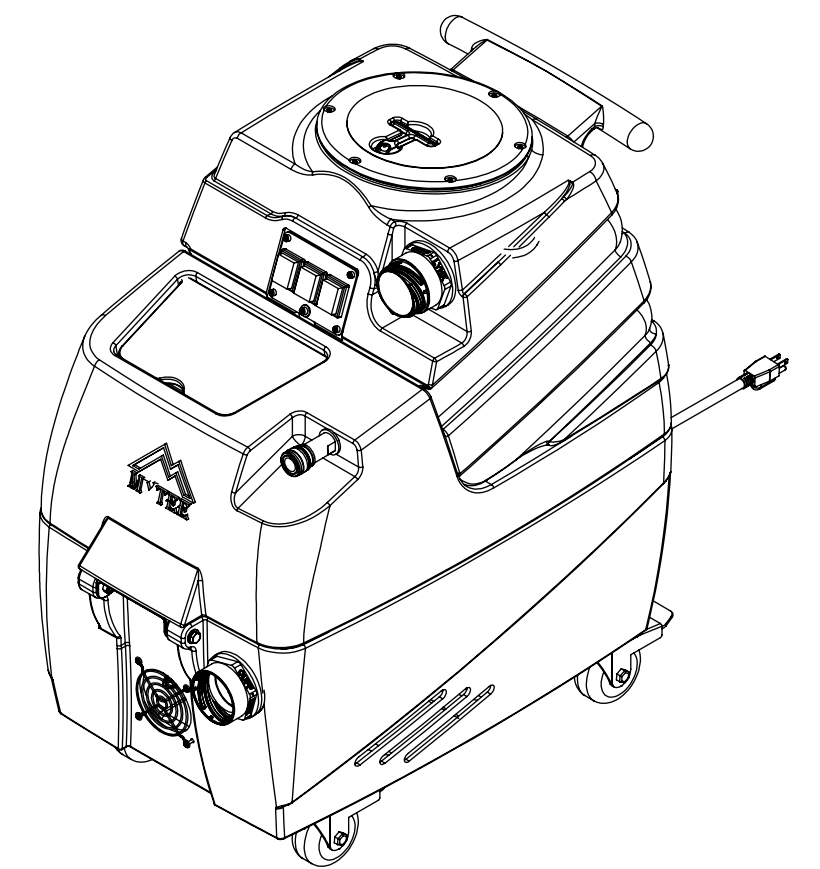

	NAME	DATE	<b>MYTEE</b> 858-679-1191	
DRAWN	V. LaBarbera	1/2014	TITLE:	
CHECKED			<b>Spyder</b>	
<small>PROPRIETARY AND CONFIDENTIAL THE INFORMATION CONTAINED IN THIS DRAWING IS THE SOLE PROPERTY OF MYTEE LLC. ANY REPRODUCTION IN PART OR AS A WHOLE WITHOUT THE WRITTEN PERMISSION OF MYTEE LLC IS PROHIBITED.</small>			SIZE	DWG. NO.
			<b>C</b>	<b>HP60</b>
			SCALE: 1:3	DO NOT SCALE DRAWING
			SHEET 5 OF 5	REV <b>F</b>